



# WQC系列小型潜水排污泵

WQC SERIES MINIATURE SUBMERSIBLE SEWAGE PUMP



**上海连成（集团）有限公司**  
SHANGHAI LIANCHENG (GROUP)CO.,LTD.

地址：上海市江桥镇曹安公路3616-3618号  
邮编：201812  
总机：(021) 59138888  
传真：(021) 59136782  
800免费咨询电话：800-820-5009  
400免费客服电话：400-188-3339

Address:3616-3618 Cao'an Road,Jiangqiao Shanghai  
P.C.: 201812  
Switchboard: (021) 5913888  
Fax: (021) 59136782  
800 Free consultation Tel: 800-820-5009  
400 Free service Tel: 400-188-3339



连成集团微信订阅号

# 目 录

## CONTENTS

<b>概 述</b> Outline	1
<b>产品特点</b> Characteristic	1
<b>产品用途</b> Purpose	1
<b>型号意义</b> Model meaning	1
<b>使用条件</b> Conditions of use	2
<b>旋转方向</b> Rotating direction	2
<b>结构说明</b> Structures description	2
<b>WQC型结构图</b> WQC type structure diagram	4
<b>WQC型泵性能参数</b> Performance parameters of type WQC pump	5
<b>WQC型泵安装方式</b> Type WQC pump installation method	6
<b>WQC型泵安装尺寸表</b> Type WQC pump installation dimension table	7
<b>WQC型泵自动耦合安装尺寸表</b> Automatic coupling installation dimension table for WQC pump	8
<b>使用、检查与维修</b> Use, check and service	10
<b>故障原因及排除方法</b> Failures causes and troubleshooting	12
<b>管路损耗参考表</b> Reference table for pipeline loss	13



## 概述 Outline

我公司最新推出的7.5kW及以下WQC系列小型潜水排污泵，是将国内同类WQ系列产品经过筛选、改进，克服其存在的不足精心设计开发而成。该系列泵的叶轮采用双流道、双叶片形式，加上独特的结构设计，使之更加可靠安全、轻便实用。整个系列产品，型谱合理，选型方便，配有潜水排污泵专用的电控柜来实现安全保护和自动化控制。

WQC series miniature submersible sewage pump below 7.5KW latest made in this Co. is meticulously designed and developed by way of screening among the domestic same WQ series products, improving and overcoming the deficiencies and the impeller used therein is double vane impeller and double runner impeller and, due to its unique structural design, can be used more reliably and safely. The products of the complete series are reasonable in the spectrum and easy to select the model and use an electric control cabinet special for submersible sewage pumps for safety protection and automatic control.

## 产品特点 Characteristic

- 1、独特的双流道、双叶片叶轮，运行平稳，过流能力好，安全无堵塞。
- 2、泵与电机同轴直接传动，属机电一体化产品，结构紧凑，性能稳定，噪声低，更加轻便适用。
- 3、采用潜水泵专用的两道单端面机械密封，轴封更可靠，寿命更长。
- 4、电机内设有油水探头等多种保护装置，保证电机更加安全的运转。

1. Unique double vane impeller and double runner impeller leaves stable running, a good flow-passing capacity and safety without block-up.
2. Both pump and motor are coaxial and directly driven. As an electromechanically integrated product, it is compact in structure, stable in performance and low in noise, more portable and applicable.
3. Two ways of the single end-face mechanical seal special for submersible pumps makes the shaft seal more reliable and the duration longer.
4. Inside of the motor there are oil and water probes etc. multiple protectors, offering the motor with a safer movement.

## 产品用途 Purpose

主要用于市政工程、楼宇建筑、工业排污、污水处理等行业场合。排送带固体颗粒及各种短纤维的污水、废水、雨水和城市生活用水。

Mainly applied in municipal engineering, building, Industrial wastewater drainage, wastewater treatment, etc. And also it's applied in handling wastewater which has solid, short fiber, stormwater and other urban domestic water, etc.

## 型号意义 Model meaning



## 使用条件 Conditions of use

- 1、介质温度不应超过40℃，介质密度 $\leq 1050\text{kg/m}^3$ ，PH值在5-9范围内。
- 2、运行时泵不得低于最低液位，参见安装尺寸图中的“▽最低液位”。
- 3、额定电压为380V，额定频率为50Hz。在额定电压和额定频率的偏差不大于 $\pm 5\%$ 时，电机才能正常运行。
- 4、通过泵的固体颗粒的最大直径不得大于泵体排出口直径的50%。

1. The medium temperature should not be over 40°C, the density  $1050\text{kg/m}^3$ , and the PH value within 5-9.
2. During running, the pump must not be lower than the lowest liquid level, see "▽ lowest liquid level".
3. Rated voltage 380V, rated frequency 50Hz. The motor can run successfully only under the condition the deviations of both rated voltage and frequency are not over  $\pm 5\%$ .
4. The maximum diameter of the solid grain going through the pump has not to be larger than 50% of that of the pump outlet.

## 旋转方向 Rotating direction

从泵体吸入口看，叶轮为逆时针方向旋转。

The impeller rotates CCW as viewed from the suction.

## 结构说明 Structures description

- 轴承:**  
选用优质的滚动轴承。其合理的轴承配置，能够延长泵的使用寿命。
- 冷却:**  
泵的冷却，采用泵抽送介质直接冷却。
- 电机:**  
电机为F级绝缘，定子最高工作温度为155℃，有效的密封使电机防护等级为IPX8。
- 机械密封:**  
选用优质的机械密封，两道单端面机械密封为电机提供双重保护。

- Bearing:**  
High-quality roll bearing, which, with a reasonable configuration, can extend the duration of the pump.
- Cooling:**  
Cooling of the pump: direct cooling by means of the pump to pump the medium
- Motor:**  
Of F class insulation, max. working temperatures 155°C, and of a protective grade IPX8 with the effective seal.
- Mechanical seal:**  
Use high-quality mechanical seal, two ways of the seal provide the motor with a dual protection.

**油 室:**

油可润滑并冷却机械密封，并具有阻止液体渗透至电机的附加安全功能。内留一定量空气可降低油室内压力的积聚升高。

**叶 轮:**

经过优化设计，排出纤维和固体能力强，输送液体使其不产生堵塞。

**泵 体:**

采用CAD/CAM技术，使泵提高效率和减少磨损。

**轴:**

泵与电机同轴

转轴悬伸设计得尽量短，降低转轴的挠度，并减少振动，延长机械密封和轴承的使用寿命，降低运行噪音。

**监控系统:**

定子内嵌有三个串联的热控开关。常温时为“常闭”状态，当定子温度达到115℃时，开关打开。

油室内装有漏水探头，用作漏水检测。当泵侧机械密封泄露，油室内的油水比例达到一定浓度，油水探头就发出报警信号（指示灯亮）并自动切断电源，使泵停止工作。

电控柜有对电机缺相进行检测的功能，以防缺相烧坏电机。

**Oil chamber:**

Oil can lubricate and cool the mechanical seal and realize the attached function of safety by preventing liquid from penetrating into the motor. The air of a certain amount left inside of the chamber can lower the pressure accumulatively raised.

**Impeller:**

The optimized design leaves the pump a powerful capacity in fiber and solid drainage and non-blocking in the liquid transportation

**Pumpcasing:**

Use of CAD/CAM know-how makes the pump an enhanced efficacy and a reduced wear.

**Shaft:**

The pump is coaxial with the motor  
The as short as possible designed stretched rotating shaft can be reduced with its deflection and vibration, extend the duration of both mechanical seal and bearing and lower the noise at running.

**Monitor system:**

Inside of the stator there are three inlaid series heat-control switches, which are in the state of "N.O." at the normal temperature and opened when the temperature on the stator gets to 115°

er-leakage probe is mounted inside the oil chamber to check water leakage and it will give a warning signal(the indicator lights), when the mechanical seal on the pump side leaks and the oil-water ratio in the oil chamber reaches a certain concentration, to automatically cut off the power to stop the work of the pump.

The function to check if the motor lack of phase is available with the electric control cabinet so as to prevent it from burning due any lack of phase.

WQC型结构图 Structure drawing

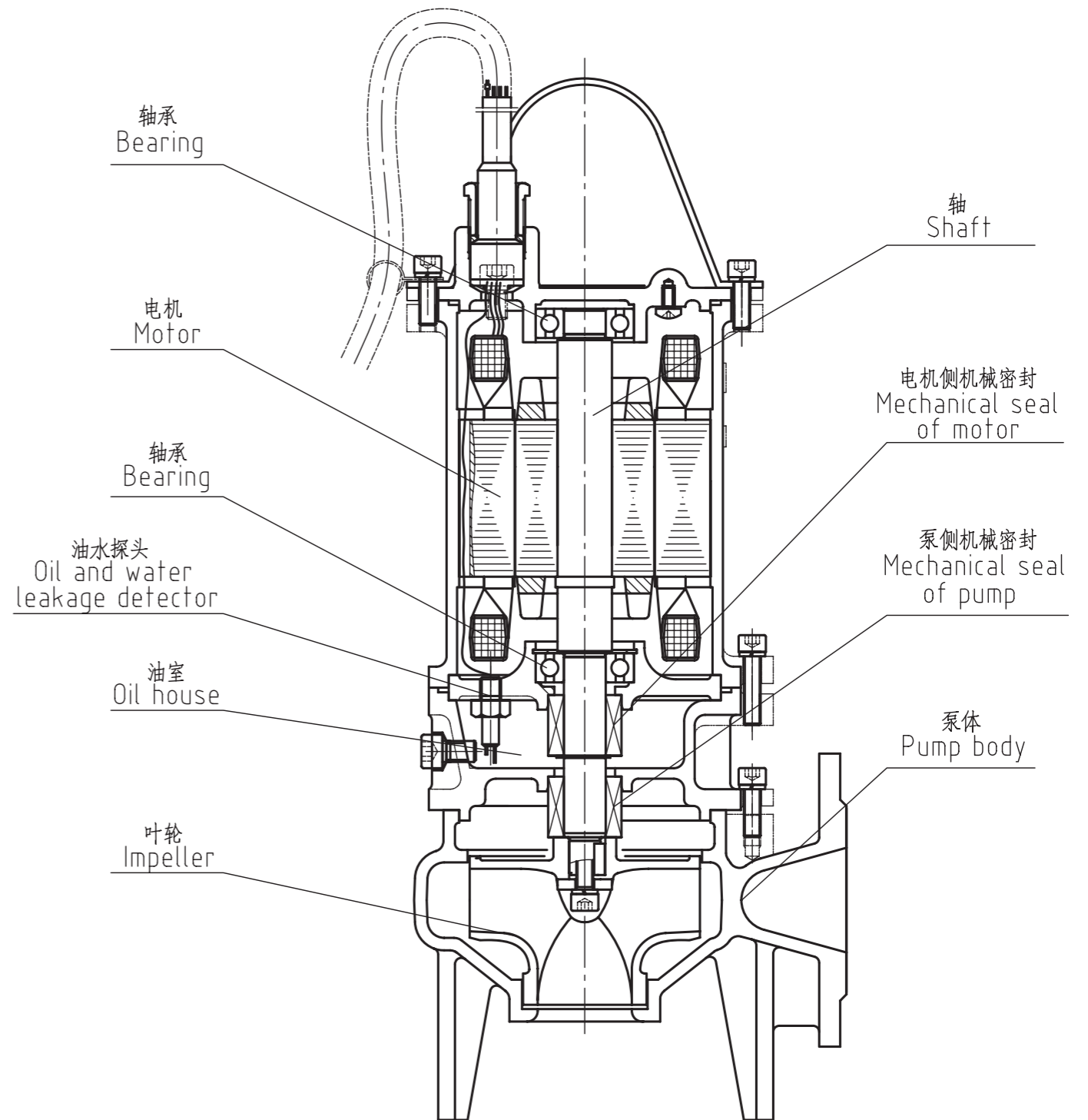

## WQC型泵性能参数Performance

序号 No.	型号 Type	排出口径 Outlet diameter (mm)	流量 Capacity		扬程 Head (m)	转速 Speed (r/min)	功率 Power (kW)	效率 Efficiency (%)	重量 Weight (Kg)
			(m³/h)	(L/s)					
1	32WQC8-10-0.75	32	6 8 10	1.7 2.2 2.8	12 10 8	2825	0.75	40 42 40	22
2	32WQC8-15-1.1	32	6 8 10	1.7 2.2 2.8	17 15 12	2825	1.1	40 42 40	23
3	50WQC15-8-0.75	50	10 15 20	2.8 4.2 5.6	9 8 6	2825	0.75	52 60 58	23
4	50WQC15-12-1.1	50	10 15 20	2.8 4.2 5.6	13 12 10	2825	1.1	47 55 54	24
5	50WQC15-16-1.5	50	10 15 20	2.8 4.2 5.6	18 16 15	2840	1.5	52 60 63	27
6	50WQC15-22-2.2	50	10 15 20	2.8 4.2 5.6	23 22 20	2840	2.2	40 51 55	29
7	50WQC15-30-3	50	10 15 20	2.8 4.2 5.6	31 30 28	2880	3	45 52 56	41
8	50WQC25-25-3	50	20 25 30	5.6 6.9 8.3	26 25 21	2880	3	55 59 62	41
9	50WQC30-20-4	50	20 30 40	5.6 8.3 11.1	25 20 16	2890	4	55 62 59	45
10	50WQC25-32-5.5	50	20 25 40	5.6 6.9 11.1	33 32 25	2900	5.5	45 51 55	66
11	50WQC25-36-5.5	50	20 25 40	5.6 6.9 11.1	38 36 30	2900	5.5	47 52 62	67
12	65WQC30-10-1.5	65	20 30 45	5.6 8.3 12.5	12 10 6	2840	1.5	55 65 55	29
13	65WQC30-15-2.2	65	20 30 45	5.6 8.3 12.5	16 15 10	2840	2.2	54 62 66	30
14	65WQC35-15-3	65	25 35 45	6.9 9.7 12.5	17 15 11	2880	3	61 66 65	40
15	65WQC30-22-4	65	20 30 45	5.6 8.3 12.5	26 22 17	2890	4	57 69 66	46
16	65WQC30-30-5.5	65	20 30 45	5.6 8.3 12.5	32 30 25	2900	5.5	46 53 61	67
17	65WQC30-35-7.5	65	20 30 45	5.6 8.3 12.5	37 35 32	2900	7.5	47 55 61	70
18	80WQC50-8-2.2	80	40 50 75	11.1 13.9 20.8	10 8 4	2840	2.2	54 65 50	35
19	80WQC50-10-3	80	40 50 75	11.1 13.9 20.8	12 10 6	2880	3	63 64 50	36
20	80WQC50-15-4	80	40 50 75	11.1 13.9 20.8	18 15 10	2890	4	61 67 65	51
21	80WQC50-20-5.5	80	40 50 75	11.1 13.9 20.8	22 20 14	2900	5.5	60 61 62	71
22	80WQC50-25-5.5	80	40 50 75	11.1 13.9 20.8	26 25 18	2900	5.5	63 69 72	72
23	100WQC80-7-3	100	65 80 100	18.1 22.2 27.8	9 7 4	2880	3	65 60 50	52
24	100WQC80-10-4	100	65 80 100	18.1 22.2 27.8	14 10 5	2890	4	65 60 50	53
25	100WQC80-13-5.5	100	65 80 100	18.1 22.2 27.8	16 13 8	2900	5.5	67 64 52	74
26	100WQC80-18-7.5	100	65 80 100	18.1 22.2 27.8	20 18 12	2900	7.5	60 59 49	76
27	150WQC150-7-5.5	150	100 150 200	27.8 41.7 55.6	10 7 3	2900	5.5	72 74 60	82
28	150WQC150-10-7.5	150	100 150 200	27.8 41.7 55.6	15 10 5	2900	7.5	73 75 60	85

## WQC型泵安装方式Installation method

### 1、自动耦合式安装

泵沿导杆放下,自动连接至排出管道系统。安装建筑费用极少,维修费用降低。

### 2、移动式硬管安装

泵由其底座支承,硬管接头与管路系统连接。

### 3、移动式软管安装

泵由其底座支承,软管接头与出水胶管相接,多用途,易于安装,水泵可轻易地从一个地方移到另一个地方。

### 1.Auto-coupled installation

The pump is placed down along with the guide rod and automatically connected to the drainage pipeline system. Less cost for mounting and lowering the cost for repair.

### 2.Movable Hard Pipe Installtion

The pump is supported by its foundation, the hard pipe joint is connected to the pipeline system.

### 3.Movable Soft Pipe Installation

The pump is supported by its foundation, the soft pipe joint is connected to the outlet rubber pipe, of multiple purposes, easy to be mounted, the pump can be easily moved from one place to another.

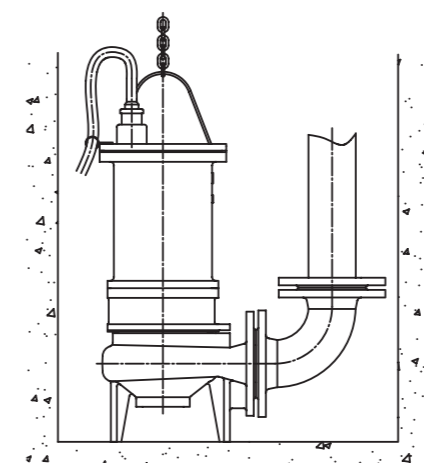

移动式硬管安装  
Movable Hard Pipe Installation

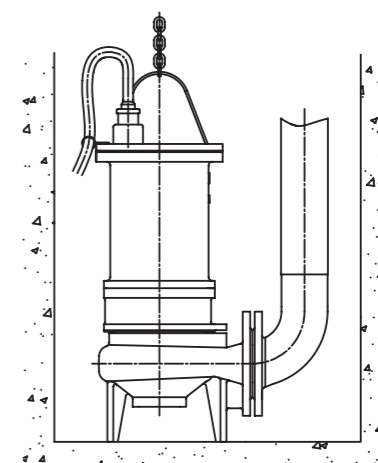

移动式软管安装  
Movable Soft Pipe Installation

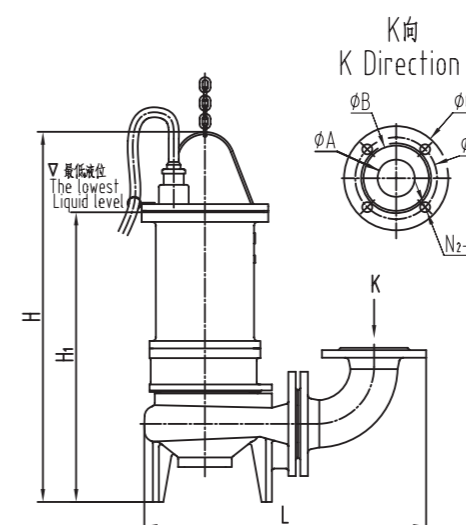

硬管联接尺寸  
Hard pipe connectoin dimension

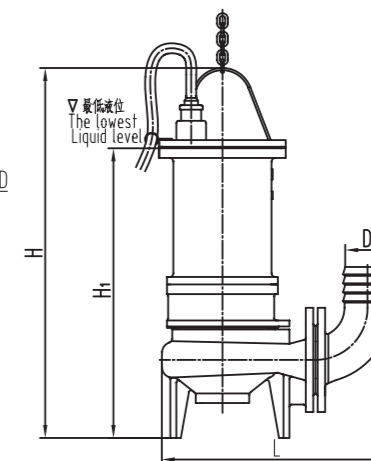

软管联接尺寸  
Soft pipe connectoin dimension



WQC型泵安装尺寸表 Installation dimension table

序号 No.	型号 Type	硬管联接尺寸 Hard pipe connection dimension							软管联接尺寸 Soft pipe connection dimension				
		ΦA	ΦB	ΦC	ΦD	N <sub>2</sub> -Φd	H	H <sub>1</sub>	L	ΦD	L	H	H <sub>1</sub>
1	32WQC8-10-0.75	32	69	120	90	4-Φ13.5	469	363	336	32	294	469	363
2	32WQC8-15-1.1	32	69	120	90	4-Φ13.5	469	363	353	32	311	469	363
3	50WQC15-8-0.75	50	90	140	110	4-Φ13.5	498	392	359	60	292	498	392
4	50WQC15-12-1.1	50	90	140	110	4-Φ13.5	498	392	377	60	310	498	392
5	50WQC15-16-1.5	50	90	140	110	4-Φ13.5	506	400	394	60	327	506	400
6	50WQC15-22-2.2	50	90	140	110	4-Φ13.5	531	425	399	60	332	531	425
7	50WQC15-30-3	50	90	140	110	4-Φ13.5	578	461	433	60	366	578	461
8	50WQC25-25-3	50	90	140	110	4-Φ13.5	578	461	433	60	366	578	461
9	50WQC30-20-4	50	90	140	110	4-Φ13.5	605	448	433	60	366	605	448
10	50WQC25-32-5.5	50	90	140	110	4-Φ13.5	614	477	466	60	399	614	477
11	50WQC25-36-5.5	50	90	140	110	4-Φ13.5	614	477	491	60	424	614	477
12	65WQC30-10-1.5	65	110	160	130	4-Φ13.5	520	414	463	74	377	520	414
13	65WQC30-15-2.2	65	110	160	130	4-Φ13.5	545	439	463	74	377	545	439
14	65WQC35-15-3	65	110	160	130	4-Φ13.5	583	466	463	74	377	583	466
15	65WQC30-22-4	65	110	160	130	4-Φ13.5	610	453	469	74	383	610	453
16	65WQC30-30-5.5	65	110	160	130	4-Φ13.5	619	482	516	74	430	619	482
17	65WQC30-35-7.5	65	110	160	130	4-Φ13.5	619	482	521	74	435	619	482
18	80WQC50-8-2.2	80	128	190	150	4-Φ17.5	574	468	530	86	416	574	468
19	80WQC50-10-3	80	128	190	150	4-Φ17.5	606	489	530	86	416	606	489
20	80WQC50-15-4	80	128	190	150	4-Φ17.5	635	478	542	86	428	635	478
21	80WQC50-20-5.5	80	128	190	150	4-Φ17.5	648	511	581	86	467	648	511
22	80WQC50-25-5.5	80	128	190	150	4-Φ17.5	648	511	581	86	467	648	511
23	100WQC80-7-3	100	148	210	170	4-Φ17.5	628	511	582	100	469	628	511
24	100WQC80-10-4	100	148	210	170	4-Φ17.5	655	498	582	100	469	655	498
25	100WQC80-13-5.5	100	148	210	170	4-Φ17.5	648	511	591	100	478	648	511
26	100WQC80-18-7.5	100	148	210	170	4-Φ17.5	648	511	591	100	478	648	511
27	150WQC150-7-5.5	150	202	265	225	8-Φ17.5	675	538	749	150	697	675	538
28	150WQC150-10-7.5	150	202	265	225	8-Φ17.5	675	538	749	150	697	675	538

WQC型泵自动耦合安装尺寸表 Auto-coupled installation dimensions table

序号 No.	型号 Type	ΦA	ΦB	ΦC	ΦD	N <sub>2</sub> -Φd	H	H <sub>1</sub>	H <sub>2</sub>	H <sub>3</sub>	h	G	J	S	T	g	f	p	y	N <sub>1</sub> -Φd
1	32WQC8-10-0.75	32	69	120	90	4-Φ13.5	469	200	50	439	20	65	105	55	255	260	310	230	210	4-Φ20
2	32WQC8-15-1.1	32	69	120	90	4-Φ13.5	469	200	50	439	20	65	105	55	265	260	310	230	210	4-Φ20
3	50WQC15-8-0.75	50	90	140	110	4-Φ13.5	498	215	50	447	20	65	105	55	248	260	310	230	210	4-Φ20
4	50WQC15-12-1.1	50	90	140	110	4-Φ13.5	498	215	50	447	20	65	105	55	258	260	310	230	210	4-Φ20
5	50WQC15-16-1.5	50	90	140	110	4-Φ13.5	506	215	50	458	20	65	105	55	268	260	310	230	210	4-Φ20
6	50WQC15-22-2.2	50	90	140	110	4-Φ13.5	531	215	50	483	20	65	105	55	268	260	310	230	210	4-Φ20
7	50WQC15-30-3	50	90	140	110	4-Φ13.5	578	215	50	516	20	65	105	55	293	260	310	230	210	4-Φ20
8	50WQC25-25-3	50	90	140	110	4-Φ13.5	578	215	50	516	20	65	105	55	293	260	310	230	210	4-Φ20
9	50WQC30-20-4	50	90	140	110	4-Φ13.5	605	215	50	503	20	65	105	55	293	260	310	230	210	4-Φ20
10	50WQC25-32-5.5	50	90	140	110	4-Φ13.5	614	215	50	532	20	65	105	55	313	260	310	230	210	4-Φ20
11	50WQC25-36-5.5	50	90	140	110	4-Φ13.5	614	215	50	532	20	65	105	55	333	260	310	230	210	4-Φ20
12	65WQC30-10-1.5	65	110	160	130	4-Φ13.5	520	240	65	489	20	80	120	55	293	285	310	250	225	4-Φ20
13	65WQC30-15-2.2	65	110	160	130	4-Φ13.5	545	240	65	514	20	80	120	55	293	285	310	250	225	4-Φ20
14	65WQC35-15-3	65	110	160	130	4-Φ13.5	583	240	65	541	20	80	120	55	293	285	310	250	225	4-Φ20
15	65WQC30-22-4	65	110	160	130	4-Φ13.5	610	240	65	528	20	80	120	55	293	285	310	250	225	4-Φ20
16	65WQC30-30-5.5	65	110	160	130	4-Φ13.5	619	240	65	557	20	80	120	55	333	285	310	250	225	4-Φ20
17	65WQC30-35-7.5	65	110	160	130	4-Φ13.5	619	240	65	557	20	80	120	55	333	285	310	250	225	4-Φ20
18	80WQC50-8-2.2	80	128	190	150	4-Φ17.5	574	275	80	560	25	70	175	90	365	290	340	255	260	4-Φ20
19	80WQC50-10-3	80	128	190	150	4-Φ17.5	606	275	80	581	25	70	175	90	365	290	340	255	260	4-Φ20
20	80WQC50-15-4	80	128	190	150	4-Φ17.5	635	275	80	573	25	70	175	90	375	290	340	255	260	4-Φ20
21	80WQC50-20-5.5	80	128	190	150	4-Φ17.5	648	275	80	601	25	70	175	90	405	290	340	255	260	4-Φ20
22	80WQC50-25-5.5	80	128	190	150	4-Φ17.5	648	275	80	601	25	70	175	90	405	290	340	255	260	4-Φ20
23	100WQC80-7-3	100	148	210	170	4-Φ17.5	628	330	100	621	25	90	215	90	405	340	410	305	310	4-Φ20
24	100WQC80-10-4	100	148	210	170	4-Φ17.5	655	330	100	608	25	90	215	90	405	340	410	305	310	4-Φ20
25	100WQC80-13-5.5	100	148	210	170	4-Φ17.5	648	330	100	636	25	90	215	90	415	340	410	305	310	4-Φ20
26	100WQC80-18-7.5	100	148	210	170	4-Φ17.5	648	330	100	636	25	90	215	90	415	340	410	305	310	4-Φ20
27	150WQC150-7-5.5	150	202	265	225	8-Φ17.5	675	485	150	745	35	125	260	90	468	480	500	440	400	4-Φ20
28	150WQC150-10-7.5	150	202	265	225	8-Φ17.5	675	485	150	745	35	125	260	90	468	480	500	440	400	4-Φ20

WQC型泵自动耦合安装尺寸表 Auto-coupled installation dimensions table

P	Q	K	L	M	e	n	m	E
90	90	331	260	210	30	18	40	700×570
90	90	348	260	210	30	18	40	700×570
90	90	322	260	210	30	18	40	700×570
90	90	340	260	210	30	18	40	700×570
98	98	357	260	210	30	18	40	700×570
98	98	362	260	210	30	18	40	700×570
113	113	396	260	210	30	18	40	850×700
113	113	396	260	210	30	18	40	850×700
118	118	396	260	210	30	18	40	850×700
130	130	429	260	210	30	18	40	850×700
130	130	454	260	210	30	18	40	850×700
98	115	396	260	210	30	18	40	850×700
98	115	396	260	210	30	18	40	850×700
113	115	396	260	210	30	18	40	850×700
118	118	402	260	210	30	18	40	900×750
130	130	449	260	210	30	18	40	900×750
130	130	454	260	210	30	18	40	900×750
101	128	480	380	320	30	18	40	850×700
113	128	480	380	320	30	18	40	850×700
118	130	492	380	320	30	18	40	850×700
130	137	531	380	320	30	18	40	900×750
130	137	531	380	320	30	18	40	900×750
113	143	532	380	320	30	18	40	900×750
118	143	532	380	320	30	18	40	900×750
130	137	541	380	320	30	18	40	900×750
130	137	541	380	320	30	18	40	900×750
146	186	635	380	320	30	18	40	950×750
146	186	635	380	320	30	18	40	950×750

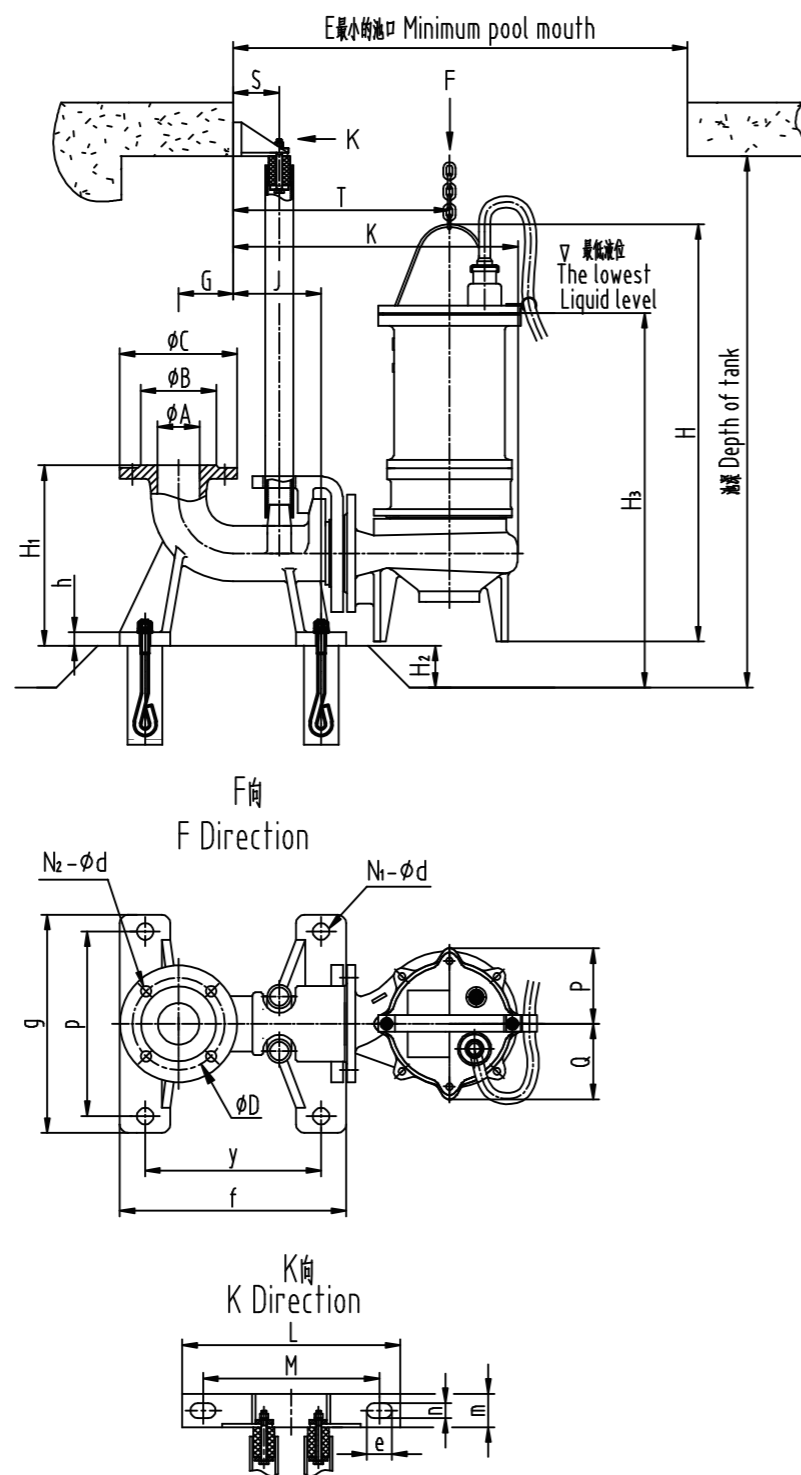

使用、检查与维修 Use, check and service

1、使用注意事项

泵不宜在易燃、易爆的介质环境中使用，也不宜抽送可燃性液体。

严禁撞击、压延电缆，严禁将电缆线当起吊绳使用。泵运行时不得随意拉扯电缆，以免损坏电缆发生触电事故或降低电缆密封性、降低电机接线腔绝缘性能。

当采用固定式自动耦合安装时，用吊链拴住提手，上下起吊泵，注意轻起轻放。

泵放入水中时应垂直起吊，不允许横放着地，更不能陷入污泥中。

吐出管路上应装流量调节阀，避免流量过大导致电机过载。

2、使用前的检查

仔细检查泵在运输、存放、安装过程中有无变形或损坏，紧固件是否松动或脱落。

检查电缆线有无破损、折断，电缆线的引出口密封是否完好，发现有可能漏电及密封不良之处应及时妥善处理。

用500V兆欧表测量电机相间和相对地间的绝缘电阻，其值不应低于50兆欧，否则应对电机定子绕组进行干燥处理，干燥处理的温度不得超过120℃。

检查油室上的螺塞和密封垫片是否齐全。检查螺塞是否已将密封垫片压紧。

检查叶轮转动是否灵活。

检查电源装置是否安全可靠、正常、检查电缆中的接地线是否已可靠接地。

泵放入池中之前须先进行点动检查转向是否正确，如转向不对，应立即切断电源，调换电控柜中接U、V、W的三相电缆中的任意两相。

1.Precautions at use

It is not proper to use the pump in a medium environment easy to explode and burn and to extract any combustible liquid.

It is strictly prohibited to impact or press the cable and use it as a lifting rope, and pull it at will when the pump is running so as not to damage it, which may result in an electric shock, or lowering the cable sealness, or the insulation performance of the wiring box of the motor.

When to use the way of fixed automatic coupling installation, lift or lower down the pump with the screw of the two hand ring and take care to handle it.

The pump has to be vertically lifted when it is placed in water and not horizontally landed, further more, not sunk into sludge.

A flow regulating valve must be equipped with the spitting pipeline to avoid overload of the motor due to a too heavy flow.

2.Check before use

Carefully check if there is any deformation or damage with the pump and any looseness or fall-off with the fasteners during transport, storage and installation.

Check if any damage or fracture with the cable, if the seal on its outlet intact and make a proper treatment in time if any possible leakage or bad seal is found.

Measure the dielectric resistance between the phases and between the phase and ground with a 500V megohm 2 meter, the value of which has not to be lower than megohm, otherwise a drying treatment must be taken for the stator winding of the motor with a temperature not over 120℃.

Check if there is oil in the oil chamber and do not stop filling it until it overflows on the filler.

Check if the screw cork and sealing pad on the oil chamber are full and if the screw cork presses the sealing pad tightly.

Check if the impeller rotates flexibly.

Check if the power device safe, reliable or normal and if the grounding wire inside of the cable reliably grounded.

Before placing the pump in the pool, check if it is in a correct. Direction of rotation by way of dot moving and cut off the power and change the U, V, W three wires with any two of which in the electric control cabinet if not correct.

3、启动

启动时应关闭吐出管路上的流量调节阀，当泵全速运转后再逐渐打开阀门。注意不能长时间在该阀门关闭的情况下运转。

4、停车

当泵停用预计达半月以上时，应将泵吊起清洗并置于干燥处。当气温较低时，应将泵提出水面并排尽泵内液体，防止冰冻。

5、定期检查

电机相间和相对地间绝缘电阻，其值不低于50兆欧，否则应拆机检修，同时应检查接地是否牢固可靠。

泵在规定的工作介质条件下正常运行半年后，应检查油室状况，如油室中的油呈乳化状态，应及时更换N10机械油。如果换油运行很短时间漏水检测探头立即报警，可能泵侧机械密封已经损坏，应更换机械密封。对于在恶劣工作条件下使用的泵，更应经常检修。

在工作条件下泵工作一年后，应进行一次大修，更换已磨损的易损件并检查紧固件，同时应补充或更换轴承润滑脂，保证泵在运行中的良好润滑。

需拆卸时不得猛敲猛打以免损坏密封件。非熟练技工不要随便拆卸泵以免造成泵泄露或电机损坏。

3.Starting

Close the flow regulating valve on the spitting pipeline at starting and gradually open it when the pump gets in the full speed running. Note the pump can not run for a long time with the valve closed.

4.Stopping

Lift the pump, clean it and place it in a dry place when intended not to use it up to half a month and lift it out of the water and let the liquid inside of it drain out to prevent it from being frozen when the temperature is very low.

5.Check

Periodically check the dielectric resistance between phases and between phase and ground, the value of which should not be lower than 2 megohm, otherwise it has to be removed to overhaul, and, at the same time, check if the grounding is secured and reliable.

After half a year running of the pump under the provided working medium condition, check the state of the oil chamber and replace it with N10 mechanical oil if it shows emulsified state. It is possible that the mechanical seal on the pump. Side is made damaged when the leakage probe gives a warning with the pump running for a short time after the oil replacement and replace it at once. More often check the pump when it is used under a very adverse working condition.

After one year work of the pump under the normal working condition, a big overhaul must be taken for replacing the worn-out parts, checking the fasteners and supplementing or replacing the grease on the bearing so as to ensure a good lubrication of the pump during its running.

To disassemble, do not knock at it at will in order to avoid damaging the seal and do not allow non-skilled persons to do that in order not cause it leaking or the motor damaged.

故障原因及排除方法 Failures causes and troubleshooting

故障现象 Failure	可能产生的原因 Possible causes	排除方法 Troubleshooting
1、流量不足或不出水 Flow not enough or not water out	a)叶轮反转 Impeller reversedly rotates b)流道堵塞 Geat blocked up c)被抽介质浓度过大 Too high concentration of the medium to be extracted d)装置扬程太高 Too high head e)叶轮严重磨损 Impeller seriously worn out	a)纠正电机转向 Correct its direction b)清除杂物 Get rid of foreign matters c)用水冲稀降低浓度 Get it thinned with water d)改泵或降低装置扬程 Change the pump or lower the head e)更换叶轮 Replace it
2、不能起动 Unable to start	a)缺相 Lack of phase b)叶轮卡住 Impeller blocked c)绕组接头或电缆断路 Circuit breaking of winding joint or cable d)定子绕组烧坏 Stator winding burnt e)电器控制故障 Electric control fault	a)检查线路 Check the circuit b)清除杂物 Get rid of foreign matters c)用欧姆表检查修复 Check and repair with an ohmmeter d)进行修理，更换绕组 Repair or replace it e)检查控制柜，修理后调换电器零件 Check electric control cabinet and replace faulty components
3、定子烧坏 Stator burnt	a)缺相运行 Running with phase lack b)被抽介质浓度过大 Too high concentration of the medium extracted c)叶轮卡死或松动 Impeller blocked or loose d)密封损坏电机进水 Seal damaged and water going in the motor e)紧固件松动造成电机进水 Fasteners loose to make water in the motor	修理好电机后，使用前必须： After repair, it is required before use: a)查清线路，清除故障 To check the circuit and clear off the failures b)用水稀释 Get it thinned with water c)清除脏物，拧紧叶轮紧固螺钉 Get rid of dirt, tighten the screws on impeller d)更换机械密封或“O”型密封圈 Replace mechanical seal or "O"-ring seal e)拧紧各部紧固件 Tighten fasteners on every part
4、电流过大 Too heavy current	a)管道、叶轮被堵 Pipeline, impeller blocked up b)抽送液体的密度或粘度较高 Too high density or viscosity of the liquid extracted c)流量过大 Too heavy flow	a)清理管道和叶轮中的堵塞物 Clear up both b)改变抽送液体的密度或粘度 Change either of both c)关小出口阀，减小流量 Close the outlet valve a little to reduce the flow



管路损耗参考表 Reference table for pipeline loss

直管摩擦损失简表(估计用)100m直管损失米数以新铸铁管为标准,旧管加倍。  
Brief table for the frictional loss of a straight pipe(for evaluation),the lost meters of a 100m straight pipe takes the newly iron pipe as the standard and multiple for the old one.

管径 Pipe diameter (mm)	流量 Capacity(L/s)									
	1	2	4	6	8	10	15	20	25	30
25	32.7	13.0								
38	3.5	14	55							
50	0.8	3.1	13	29						
65		1.6	3.2	7.1	13	20				
75		0.4	0.8	3.3	5.9	9.6	21.6			
100			0.23	0.8	1.3	2.1	6.8	8.6	13	19.4
125				0.23	0.4	0.63	1.3	2.7	4.1	5.9
150					0.16	0.26	0.58	1.1	1.6	2.3
175						0.11	0.27	0.5	0.74	1.05
200							0.13	0.26	0.37	0.53
250								0.07	0.12	0.18
300										0.07

阀门及弯管折合直管长度(每个)  
The length of a straight pipe converted into from both valve and elbow(each)

种类 Variety	折合直管直径倍数 Convert into the times of the diameter of a straight pipe	备注 Remark
标准弯管 Standard elbow	12	未畅开加倍 Multiple in case of unopen
全开闸阀 Fully opened gate valve	25	
截止阀 Back valve	100	
底阀 Foot valve	100	部分堵塞加倍 Partial block-up multiplied

注: 例如100mm直管, 底阀折合100倍直径等于100×100=10000mm=10m直径长度, 假定流量为8L/s查上表, 直管每100m损失1.3m, 则10m损失0.13m, 即一个100mm底阀, 流量为8L/s时, 损失扬程0.13m。

Note: For instance, a 100mm diameter pipe, the foot valve has a 100×100=10000mm=10m diameter when which is converted into 100 times that of the pipe's diameter. Suppose the flow is 8L/s. Looked into the above table, the loss of the straight pipe is 1.3m each 100m, then the one for 100mm is 0.13m, that is, for a 100mm foot valve with a flow 8L/s, its head low is 0.13m.

一定管径直径之最大流量限制  
Limit of the maximum flow for a pipe with a certain diameter

管径直径 Pipeline diameter (mm)	最大流量 Maximum flow (L/s)	最大流速 Maximum flow rate (m/s)	管径直径 Pipeline diameter (mm)	最大流量 Maximum flow (L/s)	最大流速 Maximum flow rate (m/s)
25	1	2.04	125	30.0	2.44
38	2.5	1.69	150	43.0	2.45
50	4.17	2.12	175	60.0	2.49
65	6.67	2.01	200	83.3	2.69
75	10.0	2.26	250	133.0	2.72
100	18.4	2.33	300	192.0	2.71

注: 超过此限使管路损失显著增加。  
Note: The pipeline loss would be made greatly increased once the limit is over.



- 南京龙源环保有限公司
- 辽阳万泰建材有限公司
- 江苏一环集团有限公司
- 岳阳鹏鹞水务有限公司
- 宁城县宏大矿业有限公司
- 衢州市污水处理厂筹建办
- 宜兴市亨得利物资有限公司
- 安徽省明光市自来水公司
- 唐山城市排水有限公司
- 铜桥港污水处理厂
- 新乡排水工程
- 山东巍桥铝电有限公司
- 灌云县南凤污水处理有限公司
- 上海凡清环境工程有限公司
- 国祯污水处理有限公司
- 铜桥港污水处理厂
- 贵州建设物资有限公司
- 烟台铂嘉机电设备有限公司
- 上海德基置业有限公司
- 宜兴市华润环保设备有限公司
- 深圳恒通源水处理科技有限公司
- 石家庄市地产集团有限公司
- 辽宁忠旺集团有限公司
- 河北康宁环保工程有限公司
- 上海东苑美墅置业有限公司
- 北京桑德环境工程有限公司
- 福州高中压仪器阀门有限公司
- 镇江市行政机关办公用房迁建工程
- 苏州天水环保机械制造有限公司
- 成都标顶商贸中心
- 海南涛天实业有限公司

- 中铁十六局
- 云南跃渊工程有限责任公司
- 沈阳工业安装工程股份有限公司
- 厦门数友科技有限公司
- 江苏环发环保设备有限公司
- 贵州绿色环保设备工程有限责任公司
- 江苏汉中建设集团有限公司苏州分公司
- 河南省漯河市双汇实业集团有限公司
- 江苏中威环境工程有限公司
- 航宇救生装备有限公司基建办公室
- 河南银鸽实业投资股份有限公司
- 三达厦门环境工程有限公司
- 上海贝瑞特机械有限公司
- 宜兴市格立环保有限公司
- 佛山安德里茨技术有限公司
- 北京华福工程有限公司
- 平原县污水处理厂
- 浙江西子置业有限公司
- 河北嘉士德金属材料销售有限公司
- 介休市新泰钢铁有限公司
- 南通二建
- 确山县水务有限公司
- 常州牡丹广景置业有限公司
- 徐州送变电有限公司器材公司
- 厦门莲花医院
- 武汉阀门水处理机械股份有限公司
- 宁东水务有限责任公司
- 长兴云宇房地产开发有限公司
- 河北康宁环保工程有限公司
- 安乐建筑工程服务(上海)有限公司
- 长沙高新开发区瑞耐博电子有限公司

- 中国海诚工程科技股份有限公司
- 大连大开市政工程有限公司
- 雄鸣环保配件经营部
- 河北康宁环保工程有限公司
- 碧泉机电设备有限公司
- 上海陆海建设有限公司
- 宜昌龙桥贸易有限公司
- 河南省通海石化设备泵阀有限公司
- 沧州杰仕利流体技术有限公司
- 广西华怡纸业业有限公司
- 淮浙煤电有限责任公司凤台发电分公司
- 江苏大唐环保工程有限公司
- 深圳建安集团
- 辽宁市政建设工程有限公司
- 上海中电能源工程有限公司
- 江苏大唐环保工程有限公司
- 沧州杰仕利流体技术有限公司
- 大钢焦化厂
- 福建榕圣市政工程有限公司
- 徐州市市政工程养护管理处
- 宜兴市亨得利物资有限公司
- 江苏鹏鹞环境工程承包有限公司
- 漯河市水利局
- 安徽三建工程有限公司
- 郑州市污水净化有限公司
- 浙江三门建安工程有限公司
- 天津城建集团有限公司
- 湖南承源国际贸易有限公司
- 海南宏安机电设备安装有限公司
- 山东临沂水利工程公司
- 河北长城建设集团有限公司

## 服务网络

连成在全国各大、中城市设有350多个分支机构，并建立了销售服务网络，拥有一支庞大的销售服务队伍。

## Service Network

With a strong team of sales promotion and after-sales-service, Liancheng established more than 350 nationwide branches in various large and middle.

## 服务项目

- 技术培训
- 设备评估
- 安装调试
- 故障处理
- 维护修理保养
- 设备升级改造

## Service Items

- Technical training
- Equipment evaluation
- Installation and adjustment
- Trouble-shooting
- Maintenance and repairing
- The modification & improvement of equipment

## 服务承诺

- 合同签约后，在安装期间本公司将派人无偿到现场协助安装及调试；
- 如您按说明书正确使用上海连成牌水泵能确保您使用满意，万一发生异常情况，即请拨打服务热线，我们将为您提供优质的售后服务，给予您满意的答复；
- 产品保修期为一年，一年之内如产品出现质量问题，本公司将实行三包；一年以后出现产品质量问题，本公司提供无偿的技术服务，需方单位自购零配件；
- 产品售出后，本公司将终生与客户保持联系，听取使用意见，以便使产品质量更加完善；
- 本公司将定期与订购单位保持联系，定期回访，以确保订购单位使用的设备运行处于良好状态。

## Service Promise

After signing the contract, technical persons will be dispatched to the instant site to help install and adjust equipment, which is free of charge.

In case the equipment is manipulated in accordance with instruction of tech manual, Shanghai Liancheng will guarantee the products. If something abnormal occurred, please contact us. Shanghai Liancheng will provide consider. Within the warrant period of 1 year, if products have quality problems, Liancheng will provide charge-free services.

After warrant period, if quality problems occur, will provide the charge-free technical support, the components and parts should be bought by customers.

After the products are purchased, Shanghai Liancheng will keep lifelong contact with the customers, listening comments from customers so as to improve quality in pump performance.

Shanghai Liancheng will keep regular contact with ordering companies so as to have pump running in proper order.

## 境内售后服务请与我公司当地售后联系或总部：021-59136786

For the domestic post-sale service, please contact the local post-sale service and the headquarter: 021-59136786

## 境外销售和售后服务请联系：+86 21 59136780

For the abroad sale and post-sale service, please contact: +86 21 59136780

驻外机构：\_\_\_\_\_

Agency : \_\_\_\_\_